



INFORMATION BULLETIN / PUBLIC - BUILDING CODE

REFERENCE NO.: LAMC 98.0501

Effective: 01-01-2020

DOCUMENT NO.: **P/BC 2020-092**

Revised:

Previously Issued As: P/BC 2017-092

TORQUE TESTING & INSTALLATION INSPECTION OF DRILLED - IN ANCHORS

INTRODUCTION

This Bulletin describes uniform criteria for the installation procedure and verification of anchors installed in existing concrete and masonry while adhering to the requirements specified by the City of Los Angeles Research Reports (LARR) and includes four types of anchors:

- EXPANSION ANCHORS
- MECHANICAL OR BEARING ANCHORS
- CHEMICAL (ADHESIVE) AND GROUTED ANCHORS
- UN-REINFORCED MASONRY (URM) ANCHORS

Note: Specification of the anchor type is the responsibility of the Design Professional of Record and must consider design issues such as quality of the base material to be anchored into and the values specified in the applicable Research Report as it relates to the specified embedment from the surface of the base material as required on the approved plans. Anchor substitutions shall be approved by the Engineer of Record and the Building Official. The applicable LARR and the approved set of plans SHALL be on site at the time of installation verification. A Registered Deputy Building Inspector with a Controlled Activity Certification of Drilled-In Concrete Anchors shall be present for all installations except that some URM anchors as described in Section VII may be tested after installation. A valid City of Los Angeles Deputy Inspector Registration for Concrete Construction, Masonry Construction, Steel Construction or Wood Construction is required to apply for a Controlled Activities Certification.

I. ISSUES CRITICAL TO ANCHOR FUNCTION:

1. Hole depth (per LARR and approved plans)
2. Hole diameter (per LARR and approved plans)
3. Interval spacing (per LARR and approved plans)
4. Edge distance (per LARR)
5. Hole cleanliness (per LARR)
6. Specific anchor brand, size and type (per approved plans)
7. Anchor initial installation embedment requirements (per LARR)

II. PRELIMINARY INSTALLATION PROCEDURE:

1. After examining the approved set of plans and checking for approval by the Building Inspector for conformance with 1 through 7 above, the Deputy Inspector shall examine the appropriate LARR for conformance to the requirements of the approved set of plans. Upon satisfaction of the above requirements, anchors shall be installed per Items E through F in Section VIII of this bulletin.
2. Verify anchoring system (anchor and component identification) for conformance to the approved plans and specifications. Notify the Engineer of Record and the Building Department of any substitutions for approval to proceed.
3. Check for obvious signs of deterioration or damage around the area to be anchored into (i.e.: cracks, honeycombing, and poor quality or spalled concrete or masonry, etc.) or damage to the rebar. Notify the Engineer of Record and the Building Department of any obvious deficiencies for an approval to proceed.
4. If holes require repositioning due to an obstruction within the structural member or in the existing structure components, then any abandoned holes shall be filled with an appropriate approved adhesive fill. Reinforcing steel shall not be cut or damaged without the written approval of the Engineer of Record.

III. REPORTING AND RECORDING INSTALLATION VERIFICATION INSPECTION RESULTS:

1. The Registered Deputy Inspector shall complete a “Registered Deputy Building Inspector’s Certificate of Compliance” form (LADBS form IN.FORM.07) when applicable that includes the following information:
 - a. Type of anchoring system and applicable Research Report number.
 - b. Number of bolts of each type installed.
 - c. Number of bolts tested or embedment torque verified of each type.
 - d. Location of tested bolts by floor and wall.
 - e. Results of testing or embedment torque for all successfully torqued anchors.
 - f. In the case of failures, unless the anchors are able to be relocated within the spacing and embedment requirements of the approved set of plans while the Registered Deputy Inspector is present and during the current inspection visit, the Registered Deputy Inspector must complete a “Deputy Correction Notice” (form IN.FORM.02) which clearly indicates the failed anchors.
2. The Registered Deputy Inspector shall leave a copy of the results of the installation, for each inspection, on the job, and be responsible for delivery of copies to the design

Professional of Record and the Contractor. The original must be delivered to the Building Official within 5 working days of the completion of the inspection.

3. In the case of unresolved failures, in addition to the reporting procedures in 1 and 2 (above), the Registered Deputy Inspector shall indicate the failed anchors on the approved set of plans, in red ink, at the appropriate location, print and sign the Inspector's name, including registration number and date. An original of the Correction Notice (Certificate of Non-Compliance) shall be delivered to the Building Official within 5 days. Copies shall be delivered to the Design Professional of Record and the Contractor and any other designated party.

IV. EXPANSION ANCHORS

Description: This category generally relies upon pressure to the side walls of the hole to develop tension and shear values and consist of the following types:

1. Torque set anchors: wedge, sleeve, and heavy-duty sleeve anchors.
2. Deformation set anchors: drop-in, stud, self-drilling, shell and drive-pin anchors.

A. General Installation Requirements

All threads, nuts, and bolts must be clean, rust and oil free, and all torquing must be done against at least one washer of the type and size specified. When installing anchors through existing members, embedment depth shall be considered as only that portion of the anchor into concrete.

1. Torque set anchors rely on minimum hole depth and accurate hole diameter. Torque set anchors must have initial embedment torque verified by Registered Special/Deputy Inspector with a Drilled-In Concrete Anchor Certification. Torque wrenches must be calibrated within one year (12 months) at the time of verification inspection by an approved Testing Agency and have the capacity to register the required torque.

“Turn of the nut” or “Double nut” method is NOT PERMITTED. Embedment torque verification is a one-time operation only and before a load is placed upon the anchor.

2. Deformation set anchors generally rely on accurate depth and diameter hole size and care must be used to ensure the proper Manufacturer's tools specified by the LARR and the Manufacturer's instructions are used for installation.

B. Installation through Wood members

Care must be taken not to damage any existing wood member or fixture while applying torque. A washer of sufficient size, a slotted steel plate, a bridging device which spans the wood member and bears on the base material or other means to distribute the force of the torquing nut against the ledger shall be used to establish initial embedment torque to prevent “cupping” of the washer and possible damage to the existing member. After torquing, the slotted plate or bridging device may be removed.

C. Obstructions

Prior to torquing anchors, verify that the anchor is not prevented from withdrawing by a base plate or other fixture. If restraint is found, loosen and shim or remove fixture(s) prior to verifying embedment torque so that accurate torque values are achieved and are not obstructed.

V. MECHANICAL OR BEARING ANCHORS

Description: These anchors are designed to expand the body of the anchor in a flared, oversized area within the hole to achieve a mechanical bond. All undercutting operations must be verified by a Registered Special/Deputy Inspector. The following are examples of these anchors:

- Standard
- Reverse or back-cut
- Self-undercutting

A. Installation requirements of mechanical or bearing anchors are as follows:

1. Undercut Anchors require that the flaring of the hole be within the minimum tolerances of the undercutting tool as specified in the COLA RR and the tolerances of the tool shall be verified with a device, such as a micrometer, or specially devised and calibrated dimensioning sleeves which allow the Inspector to determine tolerance acceptability. The tool tolerance shall be verified no less than once every ten (10) holes or as required by unusual conditions.

Note: Measuring devices capable of measuring the acceptability of the flare within the hole require the approval of the Building Official.

2. Self-undercutting anchor flaring is verified by the visual inspection of the flaring movement of the drill or with a flare measuring device, if acceptable as indicated in above note V.A.1.
3. After cleaning the hole free from dust and debris, each anchor is set and flared in the method and using the tools prescribed by the COLA RR. Embedment torque shall be verified with a calibrated torque wrench per item 1 above.

VI. CHEMICAL (ADHESIVE) GROUTED ANCHORS

Description: These materials are accompanied by Material Safety Data Sheets which should be reviewed before handling the components and necessary precautions taken for Health and Fire Hazards. This category is dependent upon the bonding of the adhesive or grout to the inside of the hole. Use of chemical adhesive products in, or as part of, fire resistant elements shall be in accordance with the applicable Research Reports.

Chemical and Grouted Anchors are of the following types:

- Capsule anchors which are self contained and are mixed in the hole with the anchor in place using an impact style drilling tool.
- Injection systems are component cartridges which are mixed and then placed.
- Grouted or dry pack anchors.

A. Installation:

1. Capsule Anchors

The specified, chisel-pointed, threaded rod is to be driven into the hole containing the specified number and size glass capsules with the specified sized roto-hammer style drill until the bottom of the hole is reached. Care must be taken not to over drill this rod. Over drilling causes the mixed components to back out of the hole. Be aware of the hardware to be connected to the installed anchor. The hardware assembly may have to be connected and in place to some degree prior to anchor installation for the final connection to be successful.

2. Chemical Cartridges

- a. Self-mixing nozzles are the most common of this type. The two components are extruded evenly by an application tool, either manual or powered, into a nozzle that has a spiral style mixer in the nozzle. Both components shall be extruded and mixed simultaneously. Cartridges shall be visually monitored and inspected for leakage. Leakage results in an incorrect proportioning of the adhesive component. When using a pneumatic applicator, manufacturer's recommended operating pressure must be maintained to avoid leakage or the bursting of the cartridges.
- b. Manually mixing style component systems must be most carefully monitored to ensure the proper mix ratios and complete mixing of the adhesive components. Once mixed, the material begins to harden and must be immediately placed without delays.
- c. The point of deposit for the mixed components shall be at the bottom of the hole, slowly withdrawing the nozzle, filling the hole as required, avoiding air pockets. An adequate quantity of adhesive must be placed in the hole before the installation of the rod or rebar to ensure that after the installation is completed the adhesive is displaced flush with the surface of the hole. If insufficient quantity of adhesive has been injected, the rod or rebar shall be removed immediately and additional adhesive injected at the bottom of the hole and the rod or rebar reinstalled with the corrected amount of adhesive material.

Note: URM anchor installations require a screen tube which shall be filled with adhesive before inserting into the anchor hole.

- d. The threaded rod or rebar shall be inserted into the hole with a counter-clockwise motion consisting of at least four (4) revolutions during installation, forcing the material back into the hole, ensuring a filled hole.

Note: The effects of gravity may cause problems with some installations. Maintaining containment of the adhesive in the hole and the positioning of the rod shall be the installer's responsibility. Horizontal holes may be drilled at a declined angle to prevent loss of adhesive with the approval of the Engineer of Record. Containment may be accomplished with slotted, plastic plugs, through which the anchor is installed into the hole, or other means to ensure the maintaining of the adhesive in the hole until setting has occurred. Plugging devices or materials must not intrude into or be considered part of the embedment requirements of the anchor.

3. Grouted Anchors

Description: Anchors installed shall be in holes solidly grouted without voids. Non-shrink grout shall be as per Los Angeles Building Code, Section 2103.3 or as approved by the City of Los Angeles Research Reports.

- a. The hole into which the non-shrink grout and anchor is to be placed must be pre-moistened immediately prior to installation.
- b. Grout shall be non-shrink and properly proportioned with the anchor installed while the material is still plastic.
- c. Re-tempering by adding additional water to non-shrink grout causes an interruption in the chemical action and is not permitted.

VII. UN-REINFORCED MASONRY (URM) ANCHORS

Description: The following Section shall be used when performing the torque tests to help determine the validity of the installation procedure and continuous inspection for installation for grouted and chemical anchors as required by Section A107.5 of the 2019 California Existing Building Code Appendix A1 and Section 8809.6 of the 2020 Los Angeles Building Code - Earthquake Hazard Ordinance and includes three basic types of anchors.

- Shear
- Combination - Shear and Tension
- 22½ ° (Combination - Shear and Tension)

Note: Impact tools or impact drills are prohibited for use in un-reinforced masonry. (2020 Los Angeles Building Code, Table 88-I, footnote 3 and 2019 California Existing Building Code Appendix A1, Table A1-E, footnote c).

A. General Installation Procedures:

1. With prior approval of the Superintendent of Building, Torque Testing may not be required for anchors installed under continuous inspection. Chemical anchors may be tested with blocking or ledger in place, if the hole in the brick wall has been drilled through the blocking or ledger and the anchor installed through that wood member. In the case of chemical combination sleeves, the metal tube must be installed flush with the surface of the un-reinforced brick. Grouted anchors may only be installed through wood if it already exists. A sheet metal sleeve with a minimum thickness of 0.16" is required before grouting and to separate the wood from the cementitious grout.
2. In accordance with California Existing Building Code Appendix A1, Section A107.5.2 and Los Angeles Building Code, Section 8809.6, one fourth of all new shear bolts and dowels embedded in un-reinforced masonry walls shall be tested by a Registered Deputy Building Inspector, using a torque calibrated wrench to the following minimum torques (including chemical adhesive combination sleeves):
 - 1/2" diameter bolts or dowels - 40 foot lbs
 - 5/8" diameter bolts or dowels - 50 foot lbs
 - 3/4" diameter bolts or dowels - 60 foot lbs

Chemical adhesive sleeves for 5/8" rods shall be tested, per Detail D, to 60 ft. lbs. torque. Testing must include a minimum of 25% per wall, per type, per room, for all URM anchors.

Examples:

- A wall with 20 shear anchors and 20 combination sleeve type anchors, 5 anchors of each type must be tested.
 - A large one room warehouse building, with 20 combination sleeve type anchors and 25 shear type anchors on one wall, would require testing of 5 combinations and 7 shear (since 25% of 25 shear anchors = 6.25 anchors, 7 is the next whole number and 7 must be tested to comply).
 - In apartments and hotels, 1 bolt of each type installed per room, per wall (excluding closets but, including bathrooms) must be tested to comply.
3. If a URM anchor or sleeve fails a torque test, 100% of all anchors installed using the system that failed, and not previously approved and documented by a Deputy Report (B-94), shall be tested.

VIII. TESTING AND INSTALLATION METHODS FOR DRILLED IN ANCHORS

A. Testing Grouted Shear Anchors (Tension Torque Test)

These anchors are installed as per Detail A in 2½" holes and using an approved non-shrink grout or dry packed as per the approved set of plans. The grout shall provide a solid bearing area for the entire length of the anchor. The anchor may be a bolt or a threaded rod with anchorage (e.g. nut). Test per Detail A.

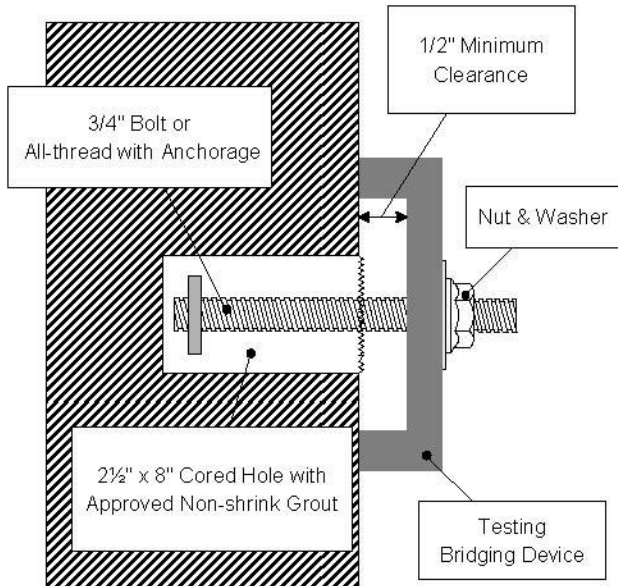

Detail A – Grouted Shear Anchor Test

A testing bridging device (as shown in this figure), which is sufficiently deep enough to allow a ½" minimum clearance and wide enough to completely span the hole while resting on the grouted area, shall be placed over the bolt. A washer and nut shall be tightened against the bridge to the required torque.

Failures

The anchor shall be considered failed if either the bolt or the grout shows any movement.

B. Testing Grouted Combination Shear and Tension Anchors (Compression Torque Test)

These anchors are installed in 2½" holes using an approved non-shrink grout or dry packed as per the approved set of plans. The grout shall provide a solid bearing area for the entire length of the anchor. Test per Detail B.

Detail B – Combination Shear and Tension Anchor Test

A 3/4" x 5/16" washer shall be placed over the bolt and against the surface of the grout only, but not against any portion of the brick. A nut shall be tightened against the surface of the washer and torqued to the required foot lbs.

Failures - An anchor shall be considered failed if the grout compresses 1/8" or more.

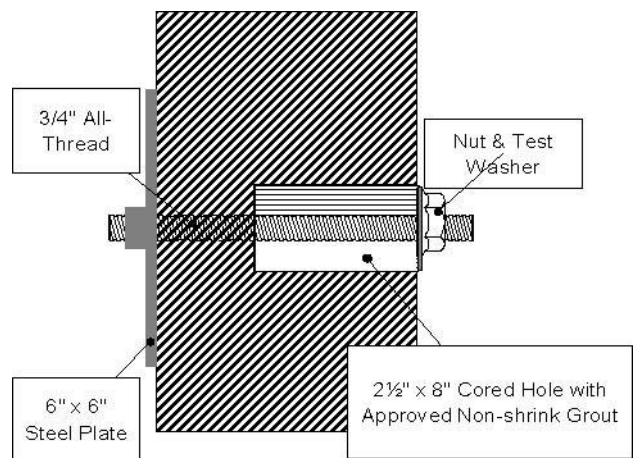

C. Testing Chemical Adhesive Combination Shear/Tension Anchors (Adhesive Bond Test)

Description: These anchors serve the same purpose as grouted combination anchors. Installation shall be per the manufacturer’s specifications and the appropriate City of Los Angeles Research Report.

Detail C – Chemical Adhesive Combination Anchor Test

A manufacturer’s recommended testing tool (example: expansion tester or Easy out tool) shall be used to test the bond between the metal tube and the adhesive. It shall fasten inside the open end of the tube in such a way as to allow testing to 60 foot lbs. without conflicting with any hardware or blocking that may be installed.

Failures

An anchor shall be considered failed if either the sleeve or the screen shows any movement.

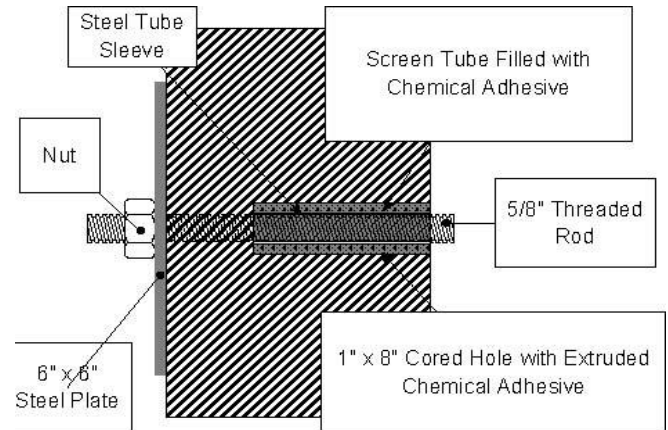

D. Testing Chemical Adhesive Shear Anchors

Description: These anchors serve the same purpose as grouted anchors. Installation shall be per the manufacturer’s specifications and the appropriate City of Los Angeles Research Report.

Detail D – Chemical Adhesive Shear Anchors Test

A testing bridging device sufficiently deep to allow 1/2" minimum clearance, and wide enough to completely span the hole so that the bridge does not rest on any part of the adhesive filled hole shall be placed over the bolt. A nut shall be tightened against the bridge.

Failures

An Anchor shall be considered failed if either the bolt or the screen shows any movement.

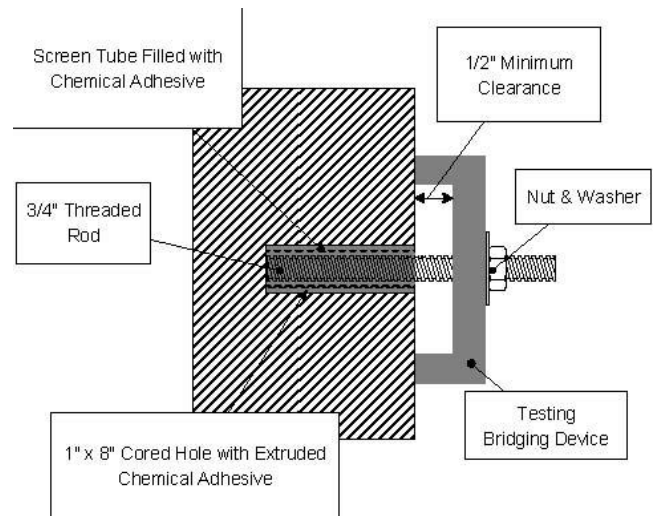

E. Installing Grouted Combination Shear/Tension Anchors at 22½°

Description: This anchor is installed in 2½” holes drilled downwards at a 22½°. The length or depth of these holes shall be equal to the width of the wall. The angle of the drilling must be carefully maintained to avoid piercing the exterior face of the wall. The anchor may be a bolt or a threaded rod with anchorage (e.g. nut).

Inclined anchors must be installed under Continuous Inspection by a Los Angeles City Registered Deputy Inspector, who is pre-qualified and certified with a Controlled Activities approval. There are no currently acceptable methods of torque testing anchors installed at 22½°. The Deputy Inspector shall ascertain that the grout material conforms to the approved set of plans and Section 2103.3 of the Los Angeles Building Code or the applicable City of Los Angeles Research Report. The Deputy Inspector must monitor all phases of the installation including the re-inspection of the hole depth, angle and cleanliness, the mixing of the grout material, the placement of the anchor and the proper filling of the hole to ensure the anchor is solidly grouted and the hole is filled.

Detail E – Grouted 22½ ° Inclined Anchor

Inclined anchors must be installed with continuous inspection. Bolt may be pre-bent (bend must occur at face of wall). With approval of the Engineer of Record, wedge washers may be used in lieu of pre-bent bolts. **BOLTS SHALL NOT BE BENT AFTER INSTALLATION.**

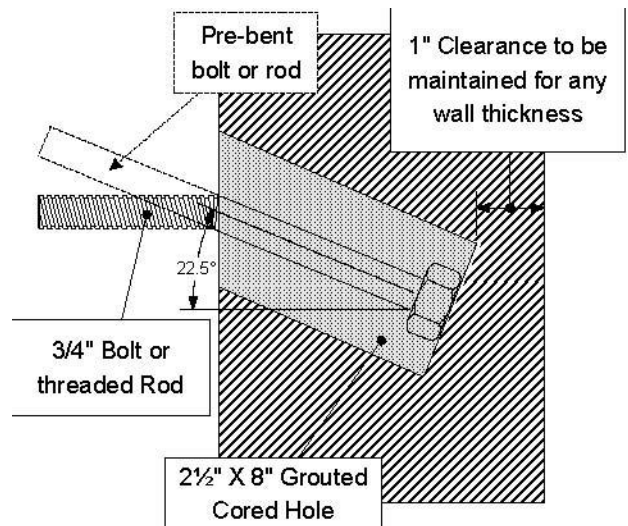

Detail E.1 – Grouted 22½° Inclined Anchor Limitations
 22½° grouted anchors shall not be installed with inclination upwards or sideways.

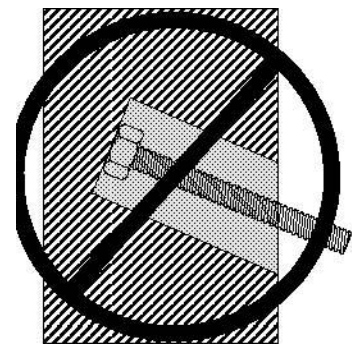

F. Installing Chemical Adhesive Combinations Shear/Tension Anchors at 22½°

Description: These anchors are installed in 1" holes drilled at 22½° upwards or downwards but not sideways. The length or depth of these holes shall be equal to the width of the wall. The angle of the drilling must be carefully maintained to avoid piercing the exterior of the wall, remaining a minimum of 1" from the exterior face.

Inclined anchors must be installed under Continuous Inspection by a Los Angeles City Registered Inspector, who is pre-qualified and certified with a Controlled Activities approval. There are no currently acceptable methods of torque testing anchors installed at 22½°. The Deputy Inspector shall ascertain that the chemical adhesive material conforms to the approved set of plans and the applicable City of Los Angeles Research Report. The Deputy Inspector must monitor all phases of the installation including the approval of the hole depth, angle and cleanliness, the mixing of the grout material, the placement of the anchor and the proper filling of the hole to ensure the anchor is solidly grouted and the hole is filled.

Detail F - Chemical Adhesive 22½° Inclined Anchors

Inclined anchors must be installed with continuous inspection. Bolt may be pre-bent (bend must occur at face of wall). With approval of the Engineer of Record, wedge washers may be used in lieu of pre-bent bolts. **BOLTS SHALL NOT BE BENT AFTER INSTALLATION.**

Note: Chemical 22½° anchors are NOT limited to downwards installation. The encapsulation of the epoxy by the screen inhibits the effects of gravity on the material, however in warm climates, containment may require additional steps per VI. A.2.

